

REV.	DATE	DESCRIPTION	DARWN BY	CHECKED BY
0	2021-10-28	INITIAL RELEASE - eCOMMRCE	VK	KW

ITEM	PART	DESCRIPTION	MATERIAL	FINISH	QTY.
1	NU M12-12.7	NUTSERT M12-12.7	STEEL 1010/1008	EX WORKS	1
2	FW M12	WASHER, FLAT, M12 x 24 OD	A2-70	EX WORKS	1
3	W M12	LOCK WASHER	A2-70	EX WORKS	1
4	HN M12	Nut, Hex, M12	A2-70	EX WORKS	1
5	AB1b-P04	SPHERICAL THREADED STUD	Gd 316 SS	MACHINED	1
6	AB1b-P09	ARTICULATING BODY	Gd 316 SS	MACHINED	1
7	AB1b-P03	CUP THREADED INSERT	G316 SS	MACHINED	1
8	AB1b-P02	Dia 50mm BACK PLATE	Gd 316 SS	FINE MACHINED	1
9	AB1b-P07	GASKET - OD50 ID25.4 x 0.8 THK.	CG605-FIBER-GREY	EX WORKS	2
10	AB1b-P05	FERRULE - OD28 ID25 x 11.5 THK.	NYLON-BLACK	MACHINED	1
11	AB1b-P01	Dia 50mm FRONT PLATE	Gd 316 SS	FINE MACHINED	1

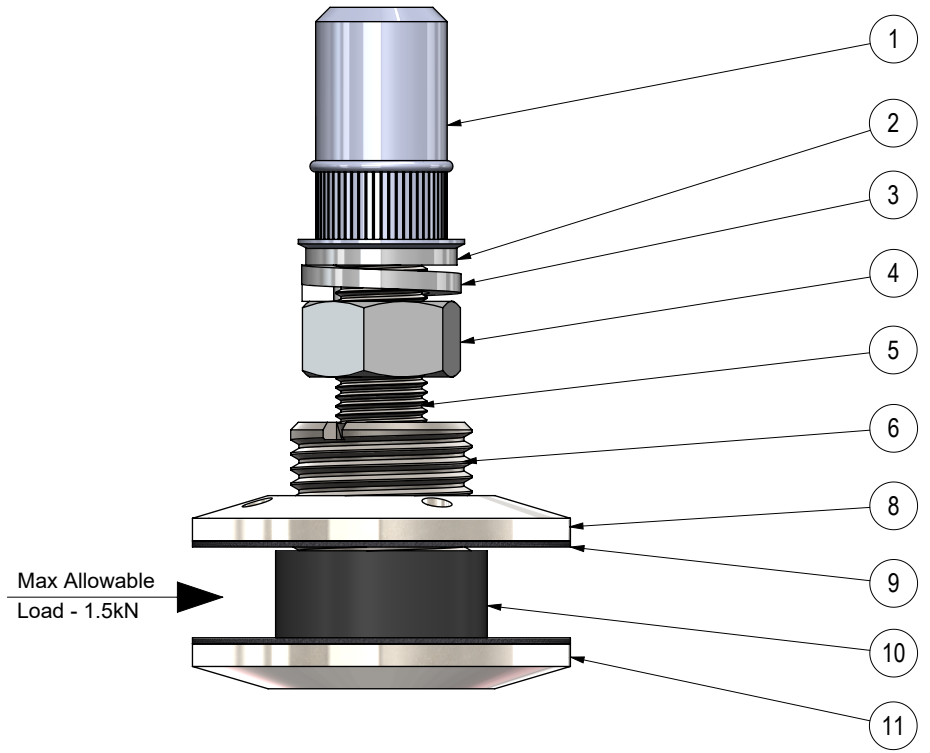

General Tolerances (ISO 8062-CT6). (mm) Unless Specified Otherwise									
NOM. DIMENSION	0 TO 10	10 TO 16	16 TO 25	25 TO 40	40 TO 63	63 TO 100	100 TO 160	160 TO 250	250 TO 400
TOLERANCE	±0.26	±0.27	±0.29	±0.32	±0.35	±0.39	±0.44	±0.50	±0.55
ANGLE TOLERANCE: ±0.5°									

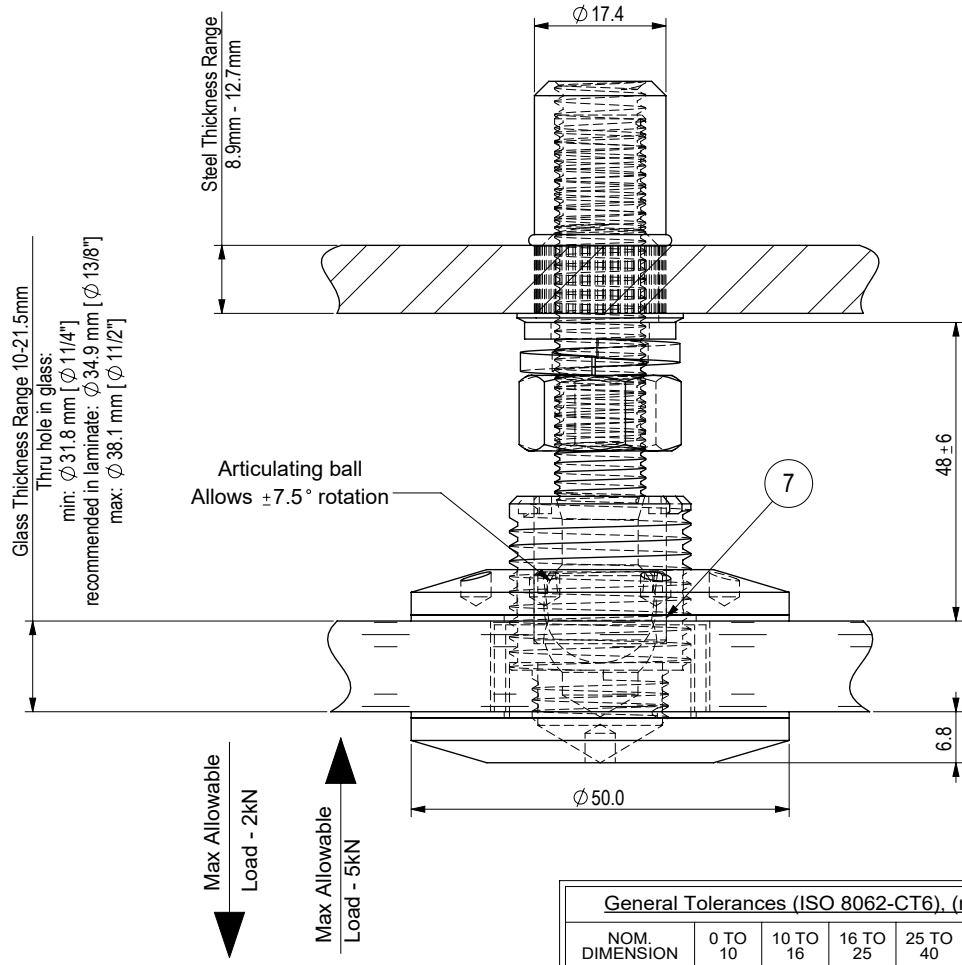
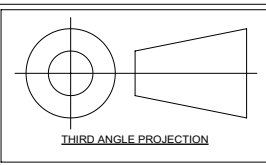

- NOTES:**
- All dimensions are in millimeters unless otherwise specified.
 - Loctite Type 243 all threads during site installation (B.O.)
(To increase curing speed, please apply activator 7649)

ASSEMBLY DRAWING - ARTICULATING BOLT - AB502TN6
STELLA GLASS HARDWARE - eCOMMERCE

SCALE	1:1
SKETCH NO.	AB502TN6



UNIT 105-8218 NORTH FRASER WAY, BURNABY, BC, V3N 0E9
 TEL (604) 231 5892
 WWW.STELLAGLASSHARDWARE.COM