

REV.	DATE	DESCRIPTION	DARWN BY	CHECKED BY
0	2021-10-28	INITIAL RELEASE - eCOMMERCE	VK	KW

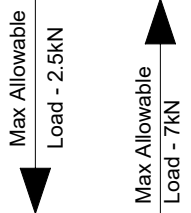

General Tolerances (ISO 8062-CT6). (mm) Unless Specified Otherwise									
NOM. DIMENSION	0 TO 10	10 TO 16	16 TO 25	25 TO 40	40 TO 63	63 TO 100	100 TO 160	160 TO 250	250 TO 400
TOLERANCE	±0.26	±0.27	±0.29	±0.32	±0.35	±0.39	±0.44	±0.50	±0.55
ANGLE TOLERANCE: ±0.5°									

ITEM	PART	DESCRIPTION	MATERIAL	FINISH	QTY.
1	AB2a-P04	END CAP NUT 802	Gd 316 SS	FINE MACHINED	1
2	FW-M16	FLAT WASHER	A2-70	EX WORKS	2
3	SW-M16	LOCK WASHER M16	A2-70	EX WORKS	1
4	HN - M16	NUT - HEX - M16	A2-70	EX WORKS	1
5	AB2a-P03	SPHERICAL THREADED STUD	Gd 316 SS	MACHINED	1
6	AB2b-P01.1	ARTICULATING CORE	Gd 316 SS	MACHINED	1
7	AB2a-P05	CUP THREAD INSERT	Gd 316 SS	MACHINED	1
8	AB2a-P02	BACK PLATE	Gd 316 SS	MACHINED	1
9	AB2a-P07	GASKET - OD58 ID32.5 x 1.6 THK.	CG608-FIBER-GREY	EX WORKS	1
10	AB2a-P06	FERRULE - OD37 ID32.5 x 11.5 THK.	NYLON-BLACK	MACHINED	1
11	AB2b-P01	Dia 60mm FRONT PLATE	Gd 316 SS	FINE MACHINED	1

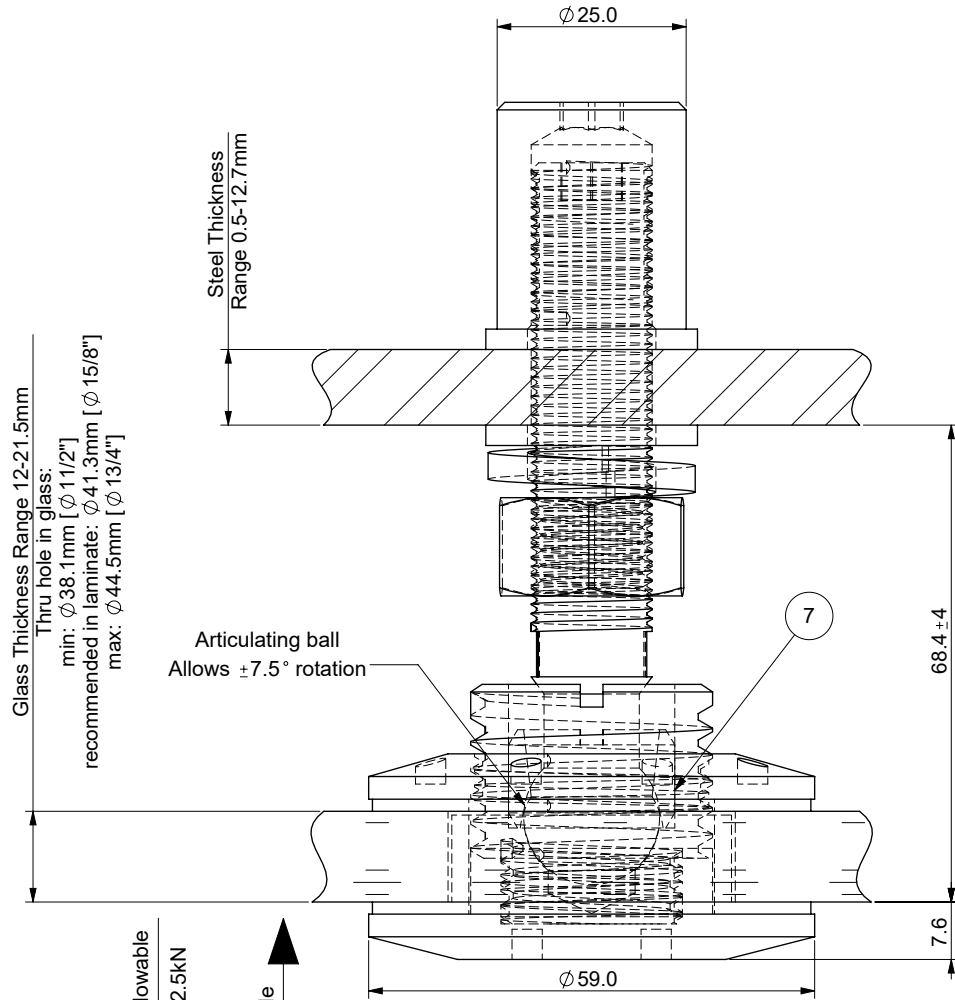
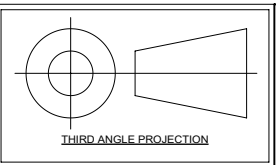
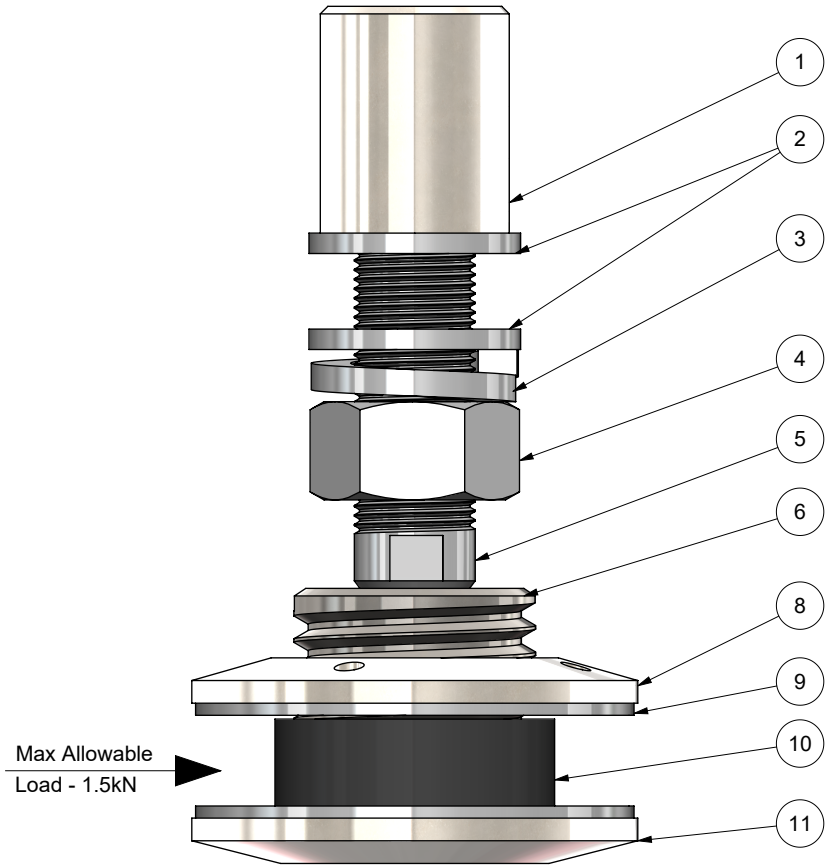

- NOTES:**
- All dimensions are in millimeters unless otherwise specified.
  - Loctite Type 243 all threads during site installation (B.O.)  
(To increase curing speed, please apply activator 7649)

**ASSEMBLY DRAWING - ARTICULATING BOLT - AB602TM6**  
**STELLA GLASS HARDWARE - eCOMMERCE**

SCALE	1:1
SKETCH NO.	
	AB602TM6

UNIT 105-8218 NORTH FRASER WAY, BURNABY, BC, V3N 0E9  
 TEL (604) 231 5892  
[WWW.STELLAGLASSHARDWARE.COM](http://WWW.STELLAGLASSHARDWARE.COM)