

REV.	DATE	DESCRIPTION	DARWN BY	CHECKED BY
0	2021-11-08	INITIAL RELEASE - eCOMMERCE	VK	KW

ITEM	PART	DESCRIPTION	MATERIAL	FINISH	QTY.
1	DP1-P02	END CAP	Gd 316 SS	MACHINED	1
2	FHCS M12	FLAT HEAD SOCKET CAP SCREW M12 (LENGTH VARIES)	A2-70	EX WORKS	1
3	DP2-P01	PIN CONNECTOR	Gd 316 SS	MACHINED	1
4	DP9-P02	DOC CONNECTOR	Gd 316 SS	MACHINED	1
5	NB1-P05a	FERRULE	NYLON-BLACK	MACHINED	1
6	NB1-P03	GASKET-1/16" THK.	CG608-FIBER-GREY	EX WORKS	2
7	NB1-P01	Dia 50 FRONT PLATE	Gd 316 SS	MACHINED	1
8	SSS M5x5	SET SCREW-HEX SOCKET- M5 X 5	A2-70	EX WORKS	1
9	FHCS M8 X 45	FLAT HEAD SOCKET CAP SECRW M8 X 45 Lg.	A2-70	EX WORKS	1

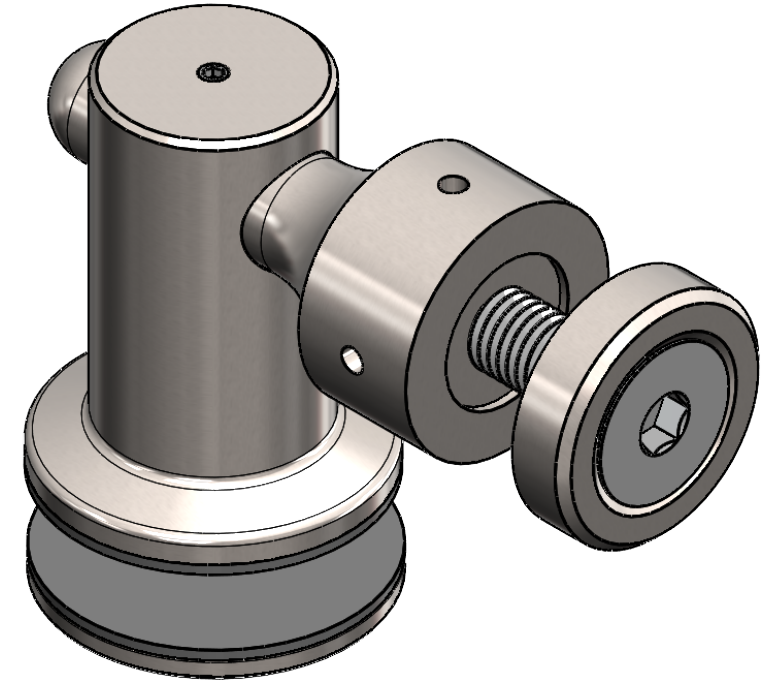
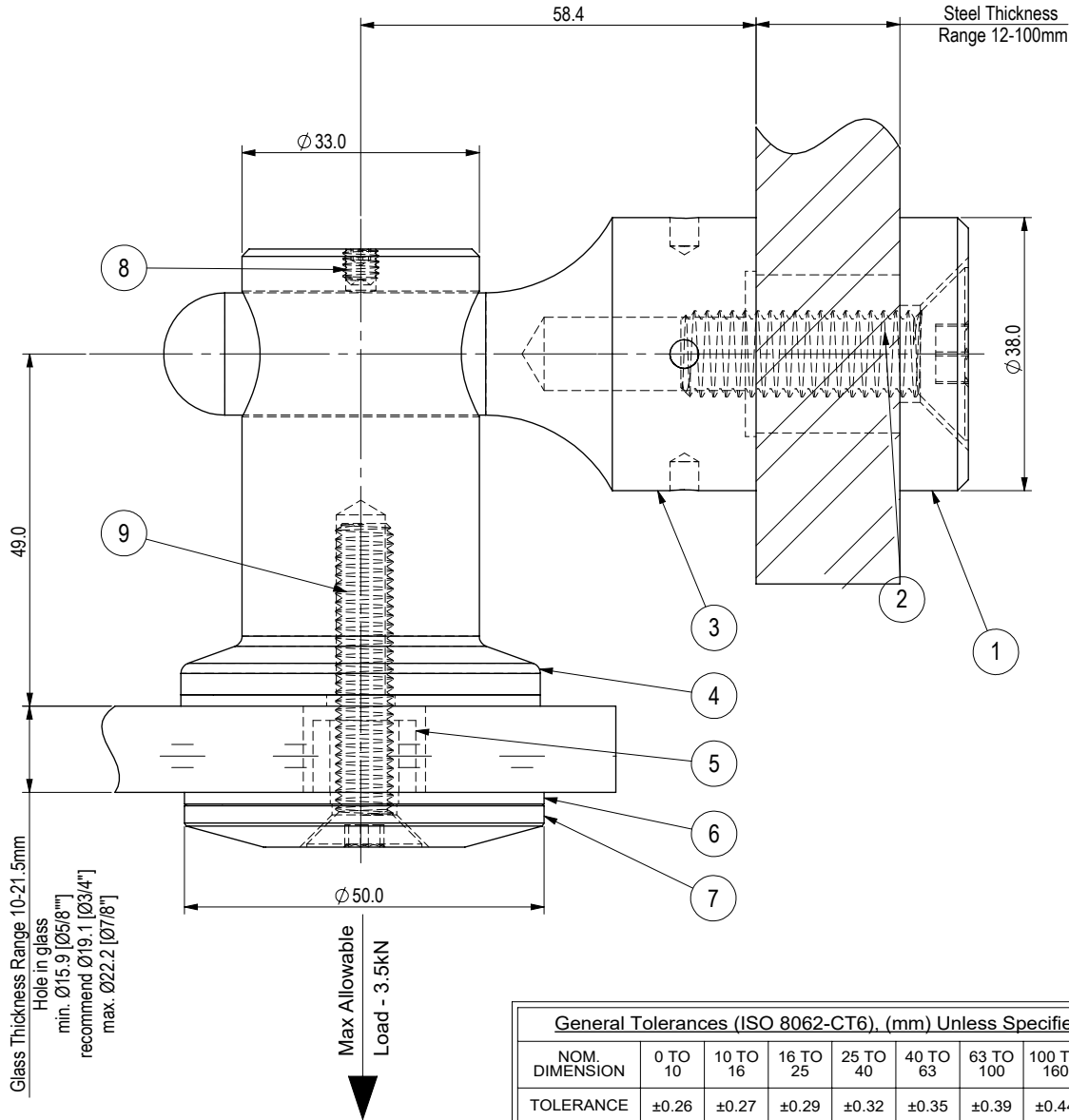

ISOMETRIC VIEW

General Tolerances (ISO 8062-CT6). (mm) Unless Specified Otherwise									
NOM. DIMENSION	0 TO 10	10 TO 16	16 TO 25	25 TO 40	40 TO 63	63 TO 100	100 TO 160	160 TO 250	250 TO 400
TOLERANCE	±0.26	±0.27	±0.29	±0.32	±0.35	±0.39	±0.44	±0.50	±0.55
ANGLE TOLERANCE: ±0.5°									

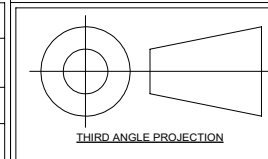

- NOTES:**
- All dimensions are in millimeters unless otherwise specified.
 - Loctite Type 243 all threads during site installation (B.O.)
(To increase curing speed, please apply activator 7649)

ASSEMBLY DRAWING - DOC & PIN - DP5021TM
STELLA GLASS HARDWARE - eCOMMERCE

SCALE	1:1
SKETCH NO.	
DP5021TM	



UNIT 105-8218 NORTH FRASER WAY, BURNABY, BC, V3N 0E9
 TEL (604) 231 5892
 WWW.STELLAGLASSHARDWARE.COM